



vaellan®
VEHICLES

TRAILER MANUAL
GEN 2

FASTENERS

Bushings (x2)
Cover studs (x6)
M6 Washer (x10)
M6X35 Hex Screw (x2)
M6X12 Bolt (x4)
M6 Nut (x14)
M8 Washer (x20)
M8X60 Bolt (x1)
M8X50 Bolt (x2)
M8X40 Bolt (x8)
M8 Nut (x11)

CONTENT

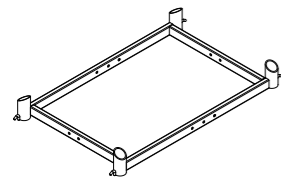

Trailer frame (x1)

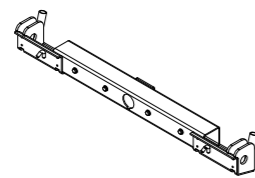

Trailer axle (x1)



End boards (x2)

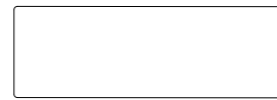

Side boards (x2)



Corner posts (x4)

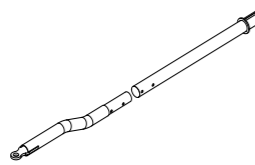

Towbar (x1)

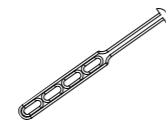

Cover strap (x6)

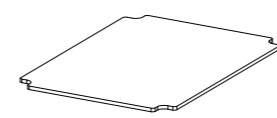

Base board (x1)

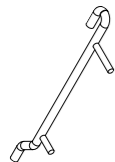

Clasp hooks (x8)

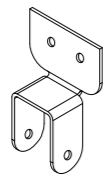

Towbar support (x1)

TRAILER MANUAL

1 ASSEMBLING THE FRAME

Attach the trailer axle and towbar support to the frame. Secure these to the frame by tightening them into place with M8X40 bolts (8 pieces).

NOTE

Place washers on both sides of the frame.

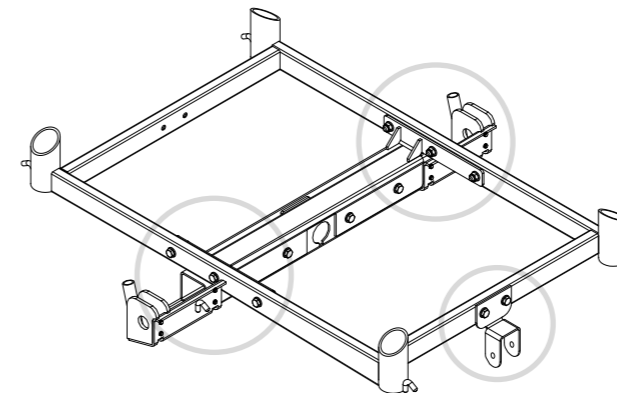

2 ASSEMBLING THE FRAME

Flip the trailer frame upside down.

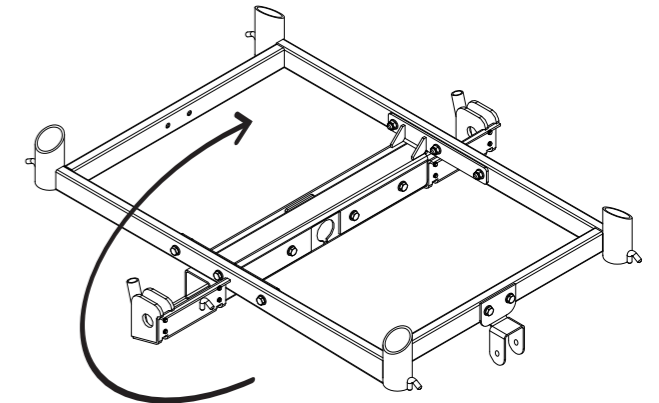

3 INSTALLING THE TOWBAR

The towbar is assembled from two parts. These two parts are fastened with two M8X50 bolts. The towbar is inserted through the axle. When the towbar has been pushed through the keyhole, turn it 180° to secure it into place.

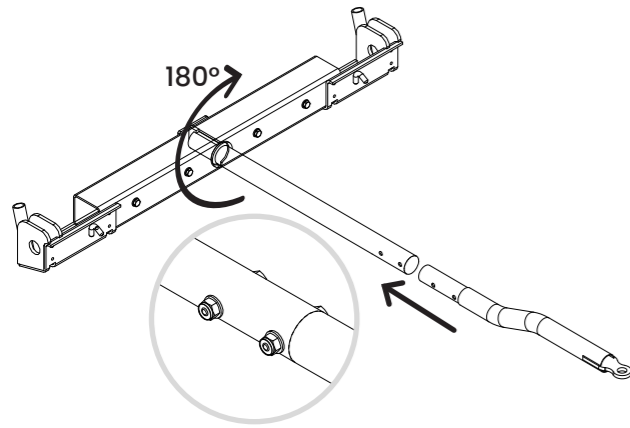

4 INSTALLING THE TOWBAR

Attach the towbar using the towbar bracket bolt (M8X60). Place a washer under the nut.

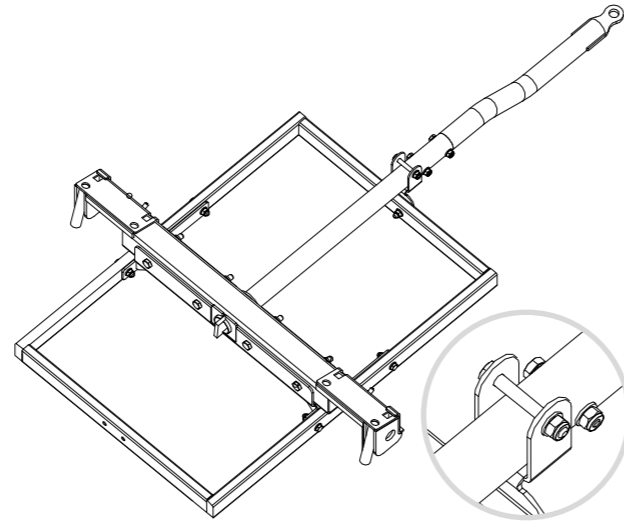

5 INSTALLING THE TOWBAR

When the towbar is in place, turn the trailer right side up.

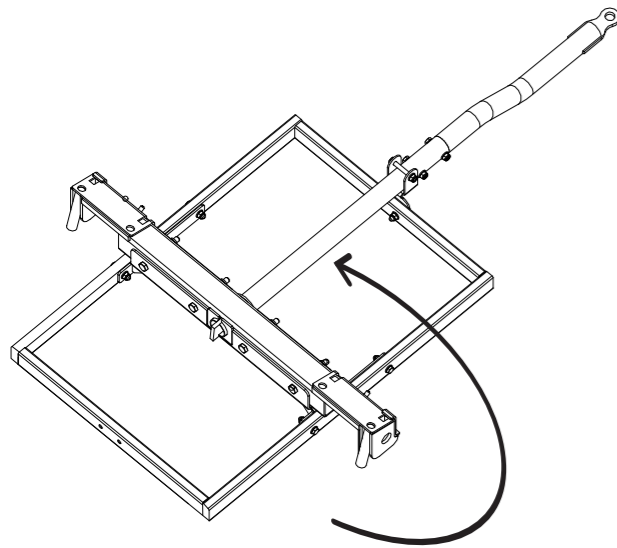

6 ATTACHING SKIS / TIRES

When the trailer is assembled, you can attach the tires or skis to the frame. If you want to install tires, you can proceed directly to step 9.

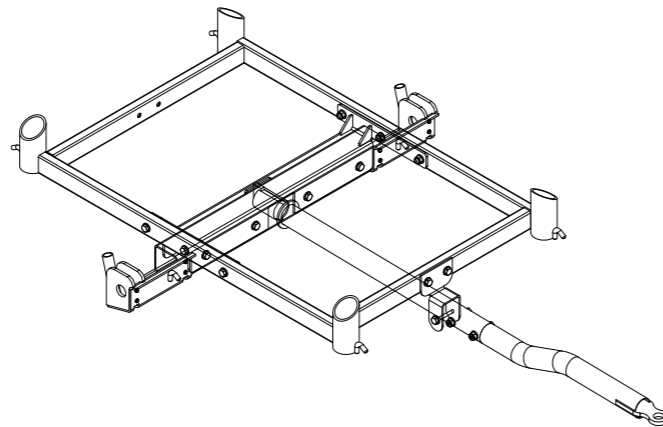

7 ATTACHING SKIS

Before you place the skis in position, remove the ski locking bars (on both ends of the axle) from the trailer axle by loosening the bolts.

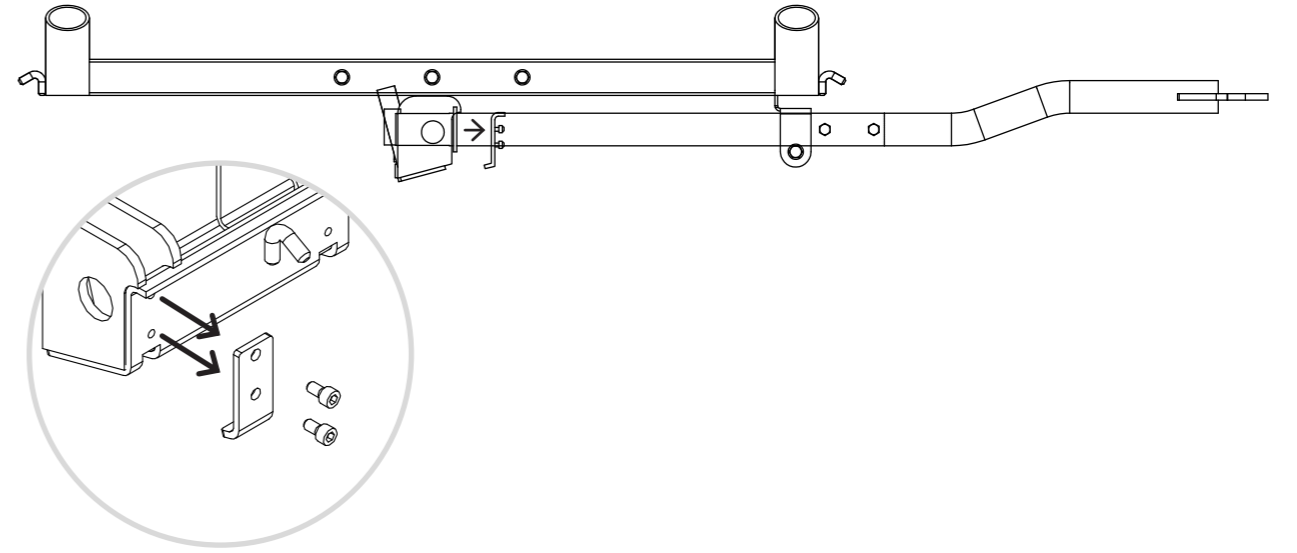

8 ATTACHING SKIS

When installing the ski, place the ski spring as shown in the following illustration. Lower the trailer and reattach the parts from step 7 (ski locking bar) to their original positions. Make sure that the ski bracket is above the locking bar.

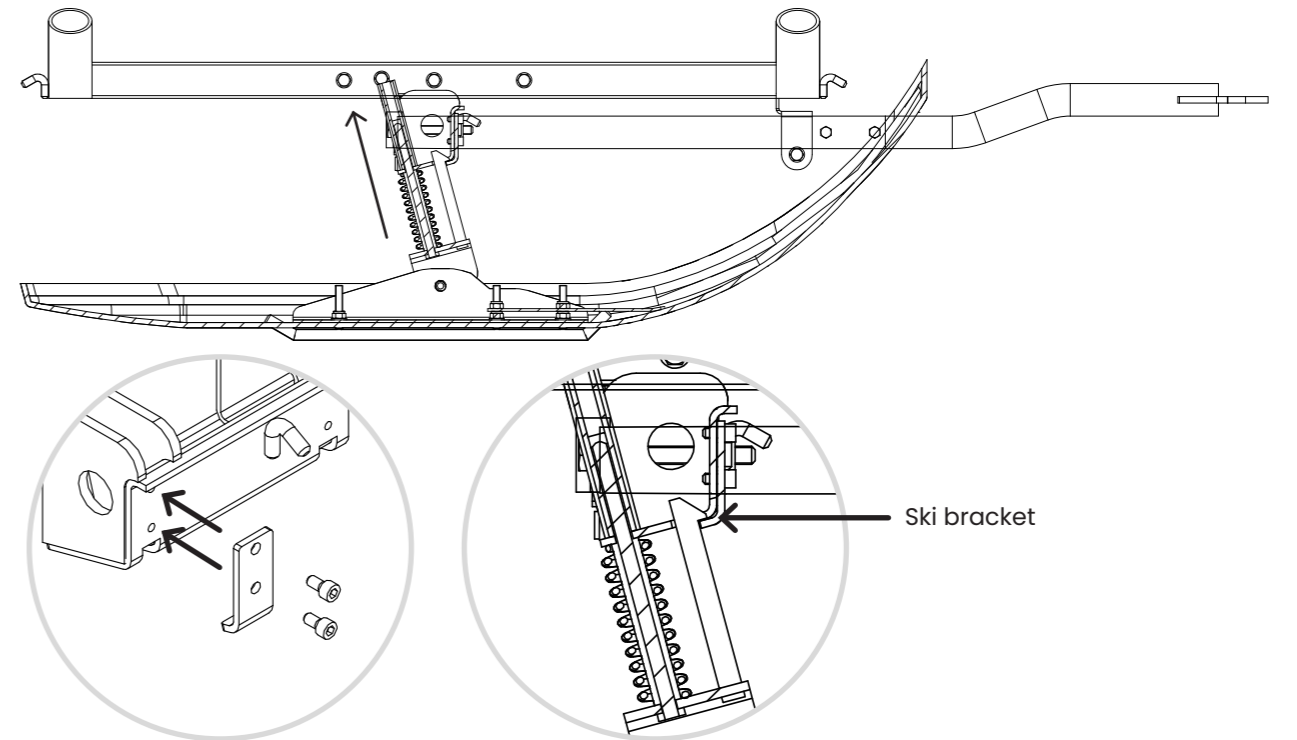

9 ATTACHING TIRES

Insert the wheel axle from the trailer frame side, so that the axle bolt faces the frame. When the axle has come out of its hole, place the wheel spacer onto the axle.

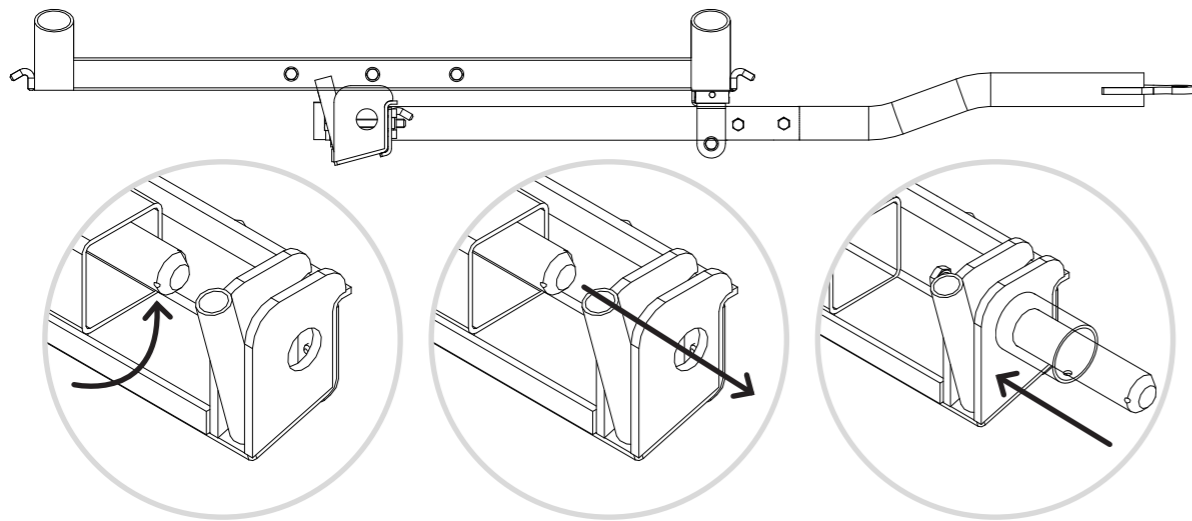

10 ATTACHING TIRES

Place the wheel on the axle. Once the wheel is on the axle, secure it in place with a cotter pin. The cotter pin is inserted through the hole in the end of the axle.

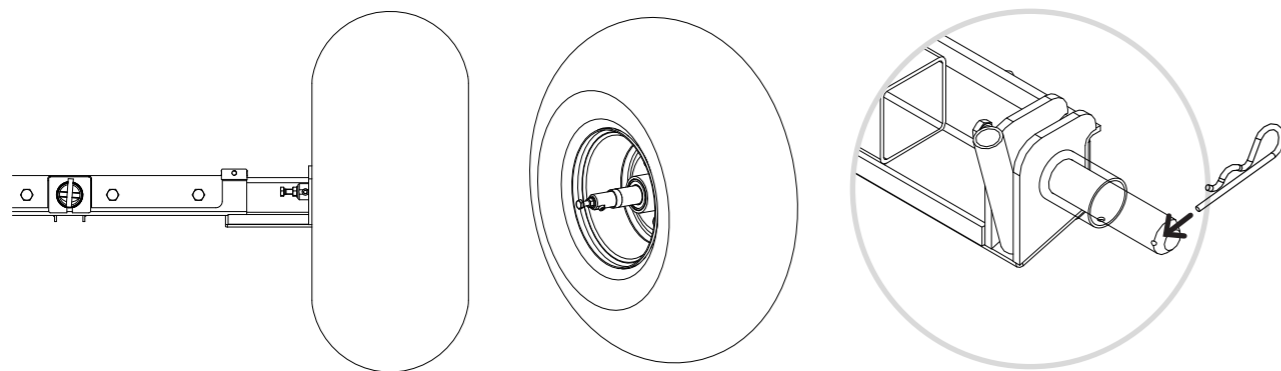

11 ASSEMBLING THE SIDE BOARD

Assemble the side boards by placing clasp hooks in their respective holes. The top threaded rod receives a cover stud and a nut. Secure the lower threaded rod with a washer and a nut. In the middle hole of the side board, insert a cover stud, and fasten it with a bolt and a nut.

NOTE

Always place a washer between the nut and the plywood.

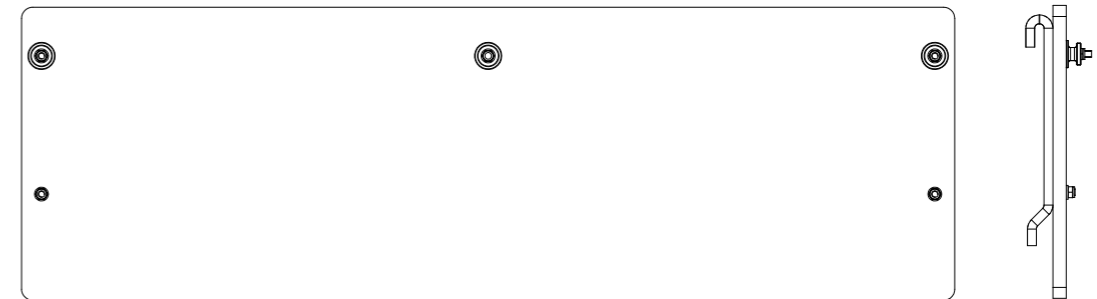

12 ASSEMBLING THE END BOARD

Assemble the end boards by placing clasp hooks in their respective holes. The top threaded rod receives a cover stud and a nut. Secure the lower threaded rod with a washer and a nut.

NOTE

Always place a washer between the nut and the plywood.

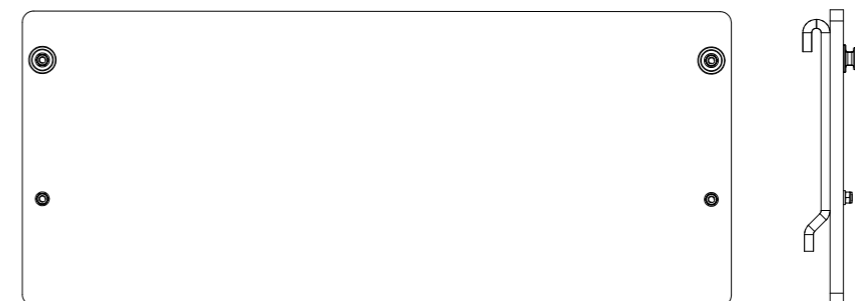

13 ASSEMBLING THE FRAME

Place the corner posts on the frame and make sure they are positioned as shown in the illustration.

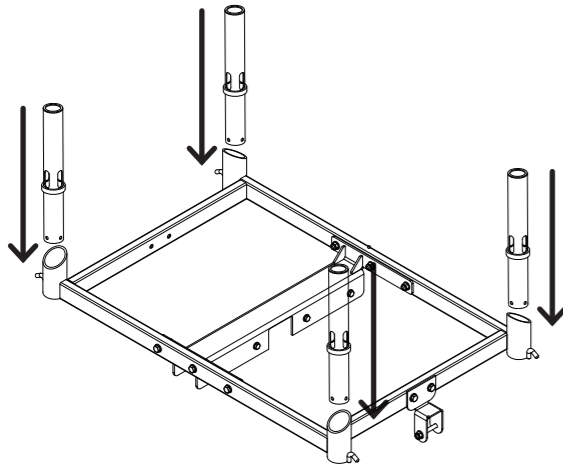

14 ASSEMBLING THE FRAME

Once the corner posts are in place, you can place the base board.

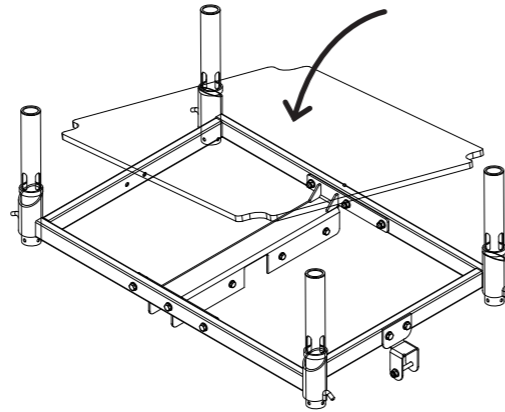

17 ASSEMBLING THE FRAME

Attach the boards into place with cover straps (attach them as marked on the following illustration).

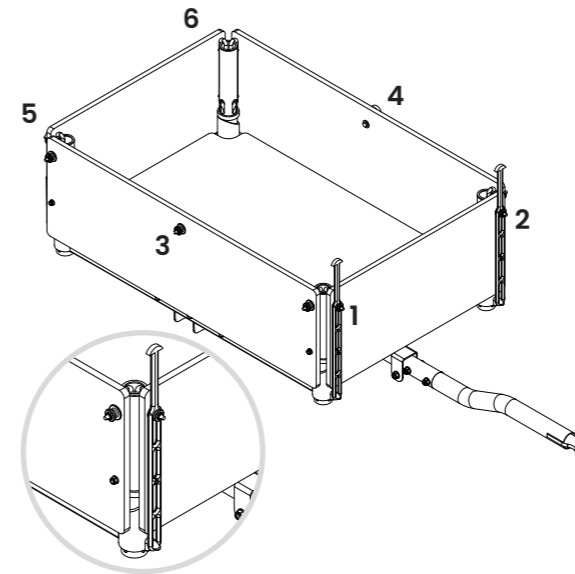

15 ASSEMBLING THE FRAME

Slide the side board along the corner posts so that the clasp hooks on the side boards align into place.

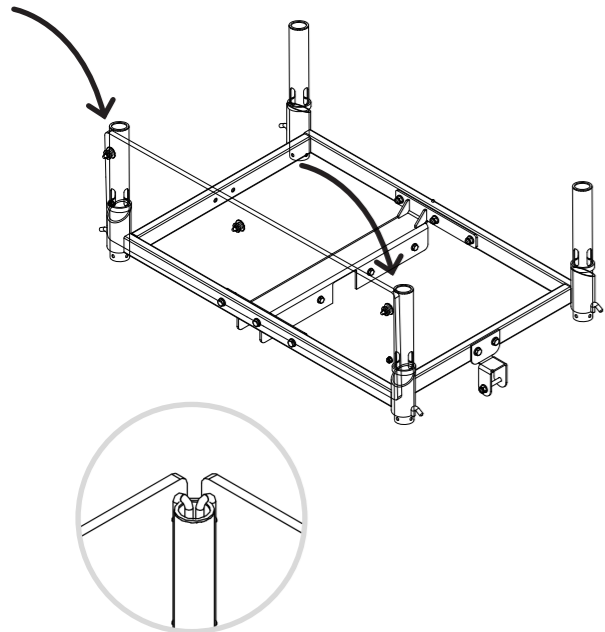

16 ASSEMBLING THE FRAME

Slide the end boards along the corner posts so that the clasp hooks on the end boards align into place.

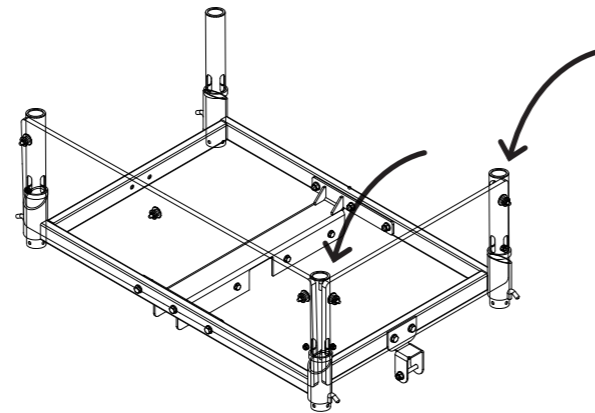

TIP

For extra support you can screw bolts into the base of the corner posts or use zipties, which ensures that the corner posts will not shift.

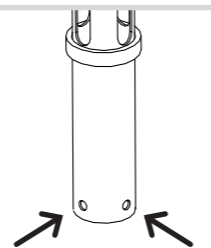

WARNING!

Transporting people and animals is prohibited.

Maximum load 80 kg.

Do not load it to be tongue-weighted.

TRAILER MANUAL
2023

www.vaellan.com



201955
Vaellan Oy
Naattiantie 1A
40520 Jyväskylä
FINLAND